

## FEATURES

- 4 digit showing the pressure in real time
- Two types signal available: 4-20mA remote signal or RS485 signal
- Good stability, anti electromagnetic interference design
- Varied pressure units available, error clearing and zero clearing
- Wide operation temperature range, wide application areas

## APPLICATIONS

- Automation equipment
- Medical equipment
- Variable frequency water supply
- Pneumatic and hydraulic system



## PRODUCT OVERVIEW

This gauge has two types outlet signal: 4-20 mA remote signal, or RS485 signal based on the standard MODBUS RTU communication protocol.

This series of remote gauge uses four digit display, showing real-time pressure. while, the pressure signal can be remoted, transmission distance more than five hundred meters.

This series of digital remote transmission pressure gauge with built-in pressure.

Sensor, has powerful function, and users can change the pressure units, zero & error clearing, correction filter constant etc.. It has followed features: 304 stainless steel shell and connector, waterproof cable outlet, waterproof grade IP65, with a very wide range of medium applicability.

The product can replace the traditional pointer type pressure gauge or pressure transmitter for transmission.

## SPECIFICATION

Range	: General Pressure Range (G): 0-2...10...16...50...100...250...400...600bar Absolute Pressure Range (GA): 0-0.05...0.1...0.2...1...10bar
Overload pressure	: 150% (>100bar) ;200% (≤100bar)
Screen type	: LCD (4-20mA), LED (RS485)
Response time	: 2 ms
Accuracy	: ±0.5% FS ±0.25% FS
Stability	: Typical: ±0.5% FS/year
Zero temperature drift	: Typical: ±0.02% FS/°C, Max ±0.05% FS/°C
Sensitivity tem drift	: Typical: ±0.02% FS/°C, Max ±0.05% FS/°C
Operating temperature	: -20...80°C
Compensation temperature	: -10...70°C
Storage temperature	: -40...100°C
Power supply	: 12-32V DC (Typical 24V)
Output signal	: 4-20 mA or RS485
Electric protection	: Reverse voltage protection, anti-electromagnetic interference
Protection level	: IP 65
Measurement medium	: Gas, Liquid
Pressure connector	: M20 X 1.5mm (Other are customized)
Shell	: 304 Stainless Steel

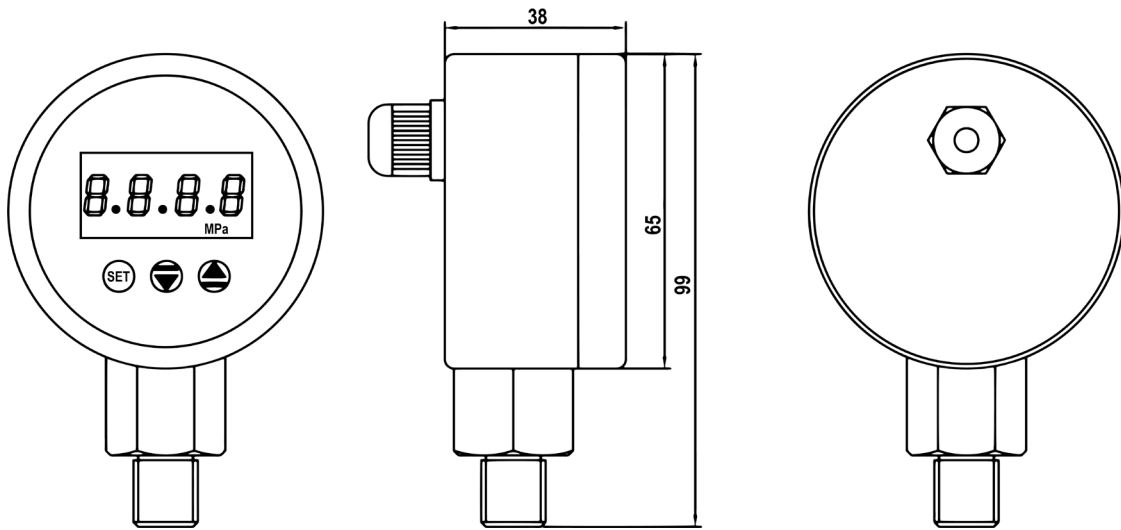

All dimensions are in mm.

ATTENTION: 4-20 mA using LCD  
RS485 using LED

### ELECTRICAL CONNECTION

4-20mA (two wire)	Power Supply (V+)	Red
	Signal (V-)	Black
RS485 Signal (Four Wire)	Power Positive(V+)	Red
	Power Negative(V-)	Black
	RS485 (S+)	Green
	RS485 (S-)	White

### ORDERING CODES

#### 1. RANGE

Xb	0-X bar	
XM	0-X MPa	1M
Xk	0-X Kpa	
Xp	0-X psi	

#### 2. ACCURACY

1	0.5% FS	1
2	0.25% FS	

#### 3. OUTLET

A	4-20mA	A
R	RS485	

#### 4. POWER

P2	24V DC	P2
----	--------	----

#### 5. MEDIUM TEMPERATURE

T1	-20...+80°C	T1
----	-------------	----

#### 6. ELECTRICAL CONNECTION

B	Fixed cable	B
C	Waterproof plug	

#### 7. SCREW

M1	M20 X 1.5mm (M)	M1
M2	G1/4" (M)	
M3	G1/2" (M)	
M4	1/2" NPT (M)	
M5	1/4" NPT (M)	
M9	Customized	

Ordering Example : PG102-1M-1-A-P2-T1-B-M1