

FEATURES

- Solid bar-stock drilled design
- 3 different shank styles
- Threaded process connection

APPLICATIONS

- Air & flue gas
- Tanks & vessels
- Oil & Gas applications
- Corrosive environments
- Power & Steel industries
- HVAC, Air filters & utilities
- On-shore/Off-shore application

Tapered Shank**STANDARD SPECIFICATIONS**

Shank form	: Tapered
Material	: AISI 316 SS
Instrument connection	: ½" NPT (F) / ½" BSP (F)
Bore diameter	: 7 mm
Lag extension	: 50 mm
Root diameter	: By order
Tip diameter	: By order
Immersion length	: By order
Tip thickness	: 5 mm
Process connection	: ½" NPT (M)

DIMENSIONAL DRAWING

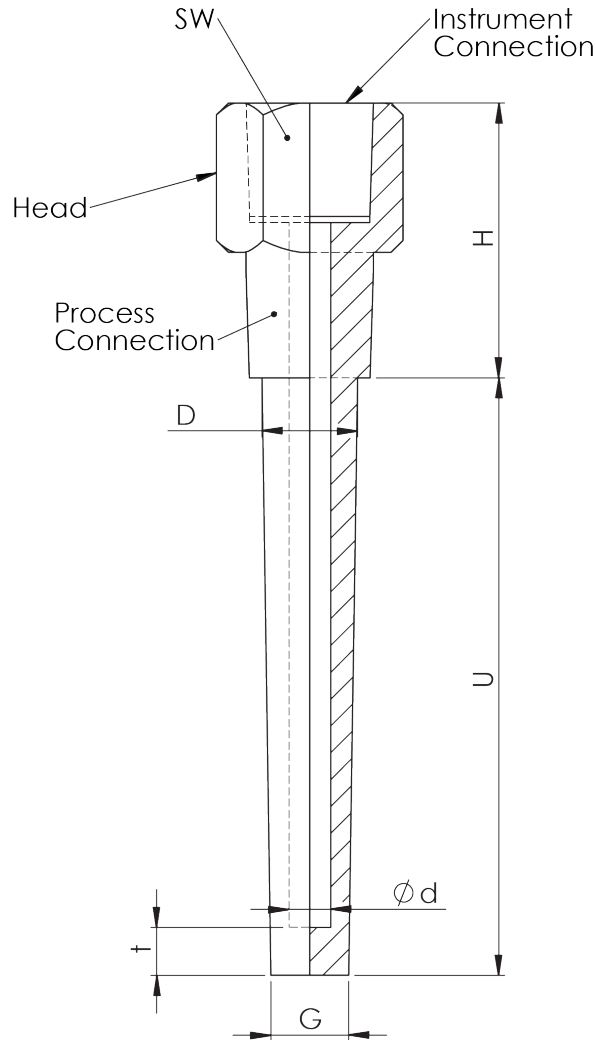

Process Connection	Head Design		Dimension in mm				
	Hexagon or round with hexagon (Metric)	Round with wrench flats (Metric)	instrument connection	D	G	Ød	H
½" NPT	HEX 27	Ø 34 mm with SW 28	• ½" NPT • ½" BSP	16	13	• 6.6 • 8.5	45
¾" NPT	HEX 27		• ½" NPT • ½" BSP	22	16	• 6.6 • 8.5	45
"1 NPT	HEX 36		• ½" NPT • ½" BSP	27	19	• 6.6 • 8.5	45

ORDERING CODES

1. SHANK FORM

T	Tapered	T
---	---------	---

2. MATERIAL

MB	Carbon Steel / ASTM A105	MG	AISI 316L SS	MB
MC	AISI 304SS	MQ	Inconel 600	
MF	AISI 316 SS	MV	Titanium	
MM	Monel			
MO	Hastelloy C-276			
MR	Inconel 625			
MI	AISI 321 SS			

3. INSTRUMENT CONNECTION

05N	¾" NPT (F)	04N	½" NPT (F)	05N
02B	¼" BSP (F)	06N	1" NPT (F)	
05B	¾" BSP (F)	04B	½" BSP (F)	
04M	M20 x 1.5 mm (F)	06B	1" BSP (F)	

4. PROCESS CONNECTION

14N	½" NPT (M)	15N	¾" NPT (M)	14N
16N	1" NPT (M)	17N	1.5" NPT (M)	
18N	2" NPT (M)	14B	½" BSP (M)	
15B	¾" BSP (M)	16B	1" BSP (M)	
17B	1.5" BSP (M)	18B	2" BSP (M)	
14M	M20 x 1.5 mm (M)			

5. HEAD SIZE

XX	Mention in 'mm'	27
----	-----------------	----

6. LAG EXTENSION ("H")

XXX	35 mm up to 250 mm	50
-----	--------------------	----

7. ROOT DIAMETER ("G")

XX.X	Mention in 'mm'	21
------	-----------------	----

8. TIP DIAMETER ("D")

XX.X	Mention in 'mm'	21
------	-----------------	----

9. BORE DIAMETER ("d")

UU	7 mm	VV	9.0 mm	UU
WW	9.6 mm	YY	11 mm	
ZZ	13 mm			

10. IMMERSION LENGTH ("U")

XXXX	50 mm up to 1000 mm	100
------	---------------------	-----

11. TIP THICKNESS ("t")

QQ	5mm	NN	6.35 mm (¼")	QQ
OO	10mm			

12. OTHER OPTIONS

XI	Plug & chain in SS	
XL	Marking by laser	XL
TC	Material test certificate	
TH	Hydro test certificate	
TN	NACE standards	
TW	WFC as per PTC 19.3TW:2010	

Ordering Example : W51-T-MB-05N-14N-27-50-21-21-UU-100-QQ-XL

NOTES

1. Other pipe/tube sizes, «U» lengths, connections are available. please contact factory for details.
2. Please refer "Technical Guidance Sheet» for the proper selection of connections according to Head size and Outer diameter of the well.