

FEATURES

- Inert gas filled
- Filled versions

APPLICATIONS

- Liquid & gaseous mediums
- Corrosive environments
- Oil & Gas applications
- Chemical & Petrochemical

Gas Actuated**STANDARD PARAMETERS**

Accuracy	: CL 1.0
Ambient temperature	: -40...70°C
Over range limits	: 110% full scale
Stem pressure rating	: 25 bar (Without thermowell)
Standard	: EN13190

MATERIAL OF CONSTRUCTION

Sensing element	: Inert Gas filled sensor bulb
Case & Ring material	: AISI 304 SS
Stem & Process connection material	: AISI 316 SS
Dial	: Aluminum, black graduation on white background
Pointer	: Micrometer zero adjustable, aluminum, black powder coated
Gaskets	: NBR
Window	: Glass

STANDARD SPECIFICATIONS

Dial size	: DN100 / DN125 / DN160
Range	: -200...+700°C
Mounting pattern	: Direct Bottom connection
Stem size	: 6.0 mm
Ingress protection	: IP 65
Assembly	: Direct
Process connection type	: Adjustable connection
Process connection	: ½" NPT (M)

Type A

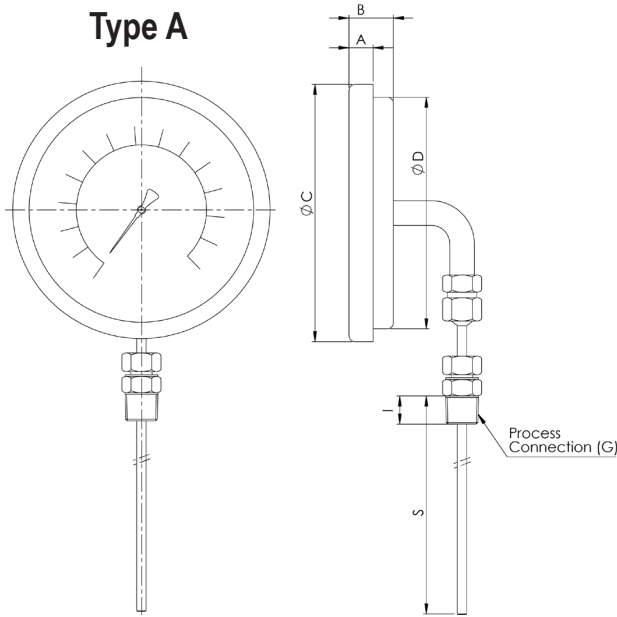

DN	A	B	C	D
100	17	49	100	98
160	18	47	160	158

Process Connection*

G	I	G	I
1/4" NPT	~14mm	1/4" BSP	~15.5mm
1/2" NPT	~20mm	1/2" BSP	~21.5mm
3/4" NPT	~19mm	3/4" BSP	~20.5mm
-	-	3/8" BSP	~17mm

*This table is for all types of TG18

Type C

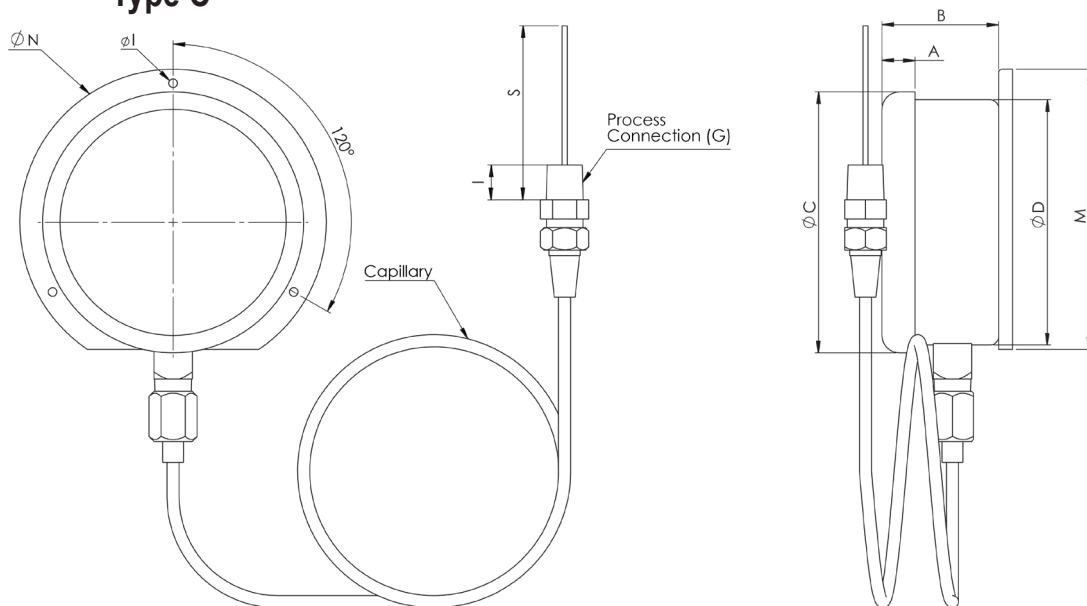

DN	A	B	C	D	M	I	U
100	17	49	100	98	***	4	132
160	18	47	160	158	184	6	196

Type E

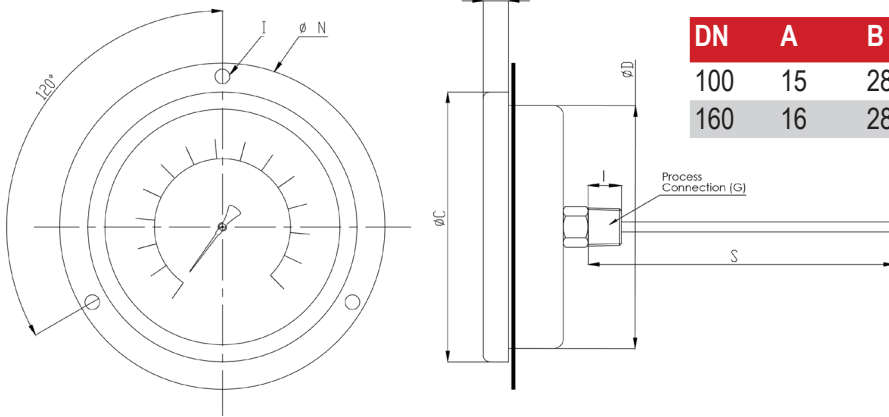

DN	A	B	C	D	I	U
100	15	28	110	100	S	4 132
160	16	28	160	148	S	6 196

Type F

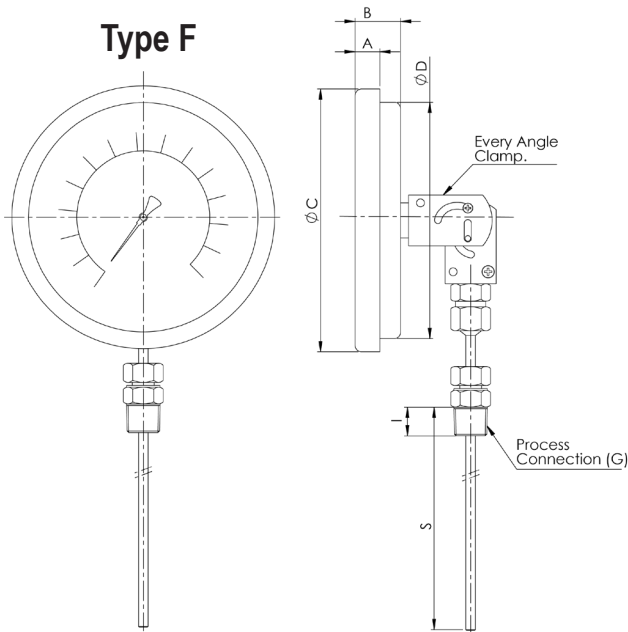

DN	A	B	C	D	E
100	15	28	110	100	S
160	16	28	160	148	S

Type J

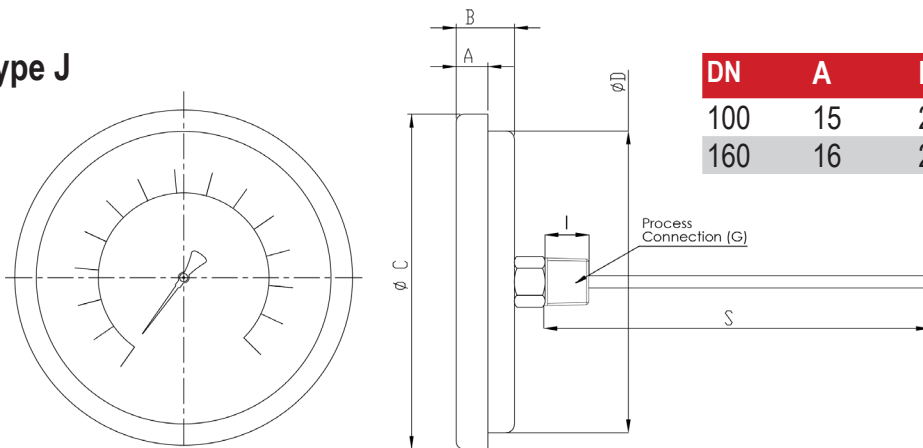

DN	A	B	C	D	E
100	15	28	110	100	S
160	16	28	160	148	S

ORDERING CODES

1. DIAL SIZE

05	100 mm / 4"	05
06	125 mm / 4½"	
07	160 mm / 6"	

2. RANGE

XXX	Refer "Range Table"	XXX
-----	---------------------	-----

3. MOUNTING PATTERN

A	Direct, Bottom connection	A
C	Wall/Surface/mounting, Bottom connection	
D	Back connection	
E	Panel/Front flange mounting, Back connection	
F	Every Angle mounting, Centre Back connection	
G	2" Pipe/Yoke mounting, Bottom connection	

4. STEM DIAMETER

HH	6.0 mm	HH
JJ	8.0 mm	
OO	10 mm	

5. INGRESS PROTECTION

ER	IP 65	ES	IP 66	ER
ET	IP 67			

6. STEM LENGTH

XXXX	Up to 2000 mm (Confirm factory before ordering)	300
------	---	-----

7. PROCESS CONNECTION TYPE

KX	Fixed connection	
KW	Adjustable connection (Sliding on stem)	KW

8. PROCESS CONNECTION

14N	½" NPT (M)	14B	½" BSP (M)	14N
12N	¼" NPT (M)	12B	¼" BSP (M)	
14M	M20 X 1.5 mm (M)	13B	3/8" BSP (M)	

9. ASSEMBLY

DR	Direct (Stem type)	DR
RE	Remote (Capillary type)	

10. CAPILLARY

MC	AISI 304 SS	MF	AISI 316 SS	MF
----	-------------	----	-------------	----

11. ARMOUR

MC	AISI 304 SS	MF	AISI 316 SS	MF
MP	PVC (Ambient max. 60°C)			

12. REMOTE MOUNTING LENGTH

XXXXX	250 mm up to 10,000 mm	10000
XXXXX	10,000 mm up to 25,000 mm	

13. OTHER OPTIONS

BA	Case & Ring in AISI 316 SS	BA
GC	Safety glass	
GW	Maximum reading pointer	
EH	Silicon oil	
TA	Calibration certificate	
TC	Material test certificate	
XF	SS tag plate, AISI 304 SS	
XG	SS tag plate, AISI 316 SS	
XT	Dial tag marking	
XR	Custom designed dial	
EG	Glycerine oil	
DS	Dual scale C/F	

Ordering Example : TG18-05-XXX-A-HH-ER-300-KW-14N-DR-MF-MF-10000-BA

NOTES

- For other ranges, connections, please contact factory.
- While selecting capillary, Bottom connections are supplied with wall mounting flange & Back connection are with Panel / front flange.
- 1/4" connections are available up to 1/4" (6.35 mm) stem diameter only.
- 3/8" connections are available up to 10 mm stem diameter only.

RANGE TABLE

RANGE(°C)	CODE
0...+50	C01
0...+60	C02
0...+80	C03
0...+100	C05
0...+120	C06
0...+160	C08
0...+250	C10
0...+300	C11
0...+400	C13
0...+500	C15
0...700	C60

RANGE(°C)	CODE
0...+600	C17
-20...+60	C20
-20...+80	C23
-30...+50	C30
-40...+60	C33
-60...+40	C49
-80...+60	C50
-200...+100	C51
-200...+50	C52