

## FEATURES

- Bimetal helix system
- External Zero adjustment

## APPLICATIONS

- Liquid & gaseous mediums
- Corrosive environments
- Oil & Gas applications
- Chemical & Petrochemical
- Food & Beverages
- Nuclear power plants

### Back connection / fixed



### STANDARD PARAMETERS

Accuracy	: CL 1.0
Ambient temperature	: -40...+70°C
Over range limits	: 110% full scale
Stem pressure rating	: 25 bar (Without thermowell)
Standard	: EN13190

### MATERIAL OF CONSTRUCTION

Sensing element	: Coiled bimetal
Case & Ring material	: AISI 304 SS
Stem & Process connection material	: AISI 316 SS
Dial	: Aluminum, black graduation on white background
Pointer	: Slotted zero adjustable, aluminum, black powder coated
Gaskets	: NBR
Window	: Glass

### STANDARD SPECIFICATIONS

Dial size	: DN100 / DN125 / DN150
Range	: -70...600°C
Mounting pattern	: Direct back connection
Stem size	: 6.0 mm
Ingress protection	: IP 65
Stem length	: 25 mm to 2000 mm*
Process connection type	: Adjustable connection
Process connection	: ½" NPT (M)

\* Depending on range & stem diameter

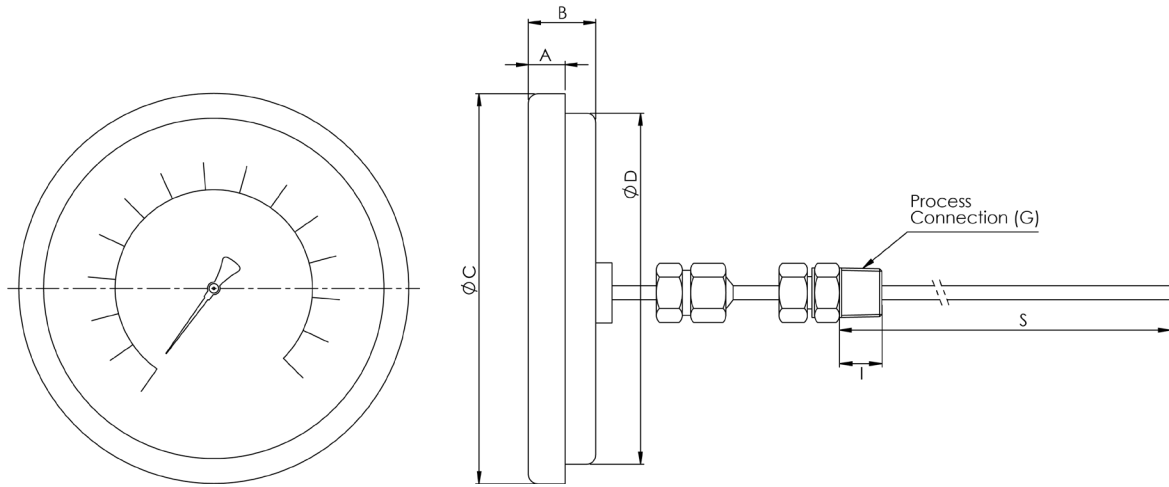

Process Connection			
G	I	G	I
1/4" NPT	~14mm	1/4" BSP	~15.5mm
1/2" NPT	~20mm	1/2" BSP	~21.5mm
3/4" NPT	~19mm	3/4" BSP	~20.5mm
-	-	3/8" BSP	~17mm

DN	A	B	C	D	E
100	15	28	110	100	S
125	15	28	130	125	S
160	16	28	160	148	S

### STEM LENGTH CHART

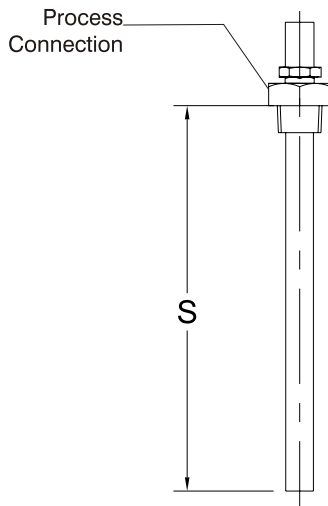

Stem Diameter	6 mm & 1/4"	8 mm	10 mm	12 mm
Range (°C)	Min. Stem Length (mm)			
0...50	130	110	110	110
0...60	110	95	95	95
0...80	95	70	70	70
0...100	75	70	70	70
0...120	70	60	60	60
0...150	60	50	50	50
0...200	50	45	45	45
0...250	40	35	35	35
0...300	60	50	50	50
0...400	50	45	45	45

1. All length mentioned above are to be considered below thread only.
2. For other reduced length, contact factory before ordering.

### NOTES

1. DN50 is available in Centre back connection (R0) only.
2. Equivalent scales available in °F, °C/°F, °F/°C. Please contact factory for details.

### ORDERING CODES

#### 1. DIAL SIZE

05	100 mm / 4"	05
06	125 mm / 4½"	
07	160 mm / 6"	

#### 2. RANGE

XXX	Refer "Range Table"	XXX
-----	---------------------	-----

#### 3. MOUNTING PATTERN

D	Direct / Back connection	D
---	--------------------------	---

#### 4. STEM DIAMETER

HH	6.0 mm	HH
JJ	8.0 mm	
OO	10 mm	

#### 5. INGRESS PROTECTION

ER	IP 65	ER
ET	IP 67	

#### 6. STEM LENGTH

XXXX	Up to 2000 mm	150
------	---------------	-----

#### 7. PROCESS CONNECTION TYPE

KX	Fixed connection	
KW	Adjustable connection (Sliding on stem)	KW

#### 8. PROCESS CONNECTION

14N	½" NPT (M)	14N
14B	½" BSP (M)	
12N	¼" NPT (M) <sup>3</sup>	
12B	¼" BSP (M) <sup>3</sup>	
14M	M20 X 1.5 mm (M)	
13B	3/8" BSP (M) <sup>4</sup>	
15N	¾" NPT (M)	
15B	¾" BSP (M)	
04N	½" NPT (F)	
05N	¾" NPT (F)	
16M	M27 X 2.0 mm (M)	

#### 9. OTHER OPTIONS

BA	Case & Ring in AISI 316 SS	BA
GC	Safety glass	
EH	Silicon oil	
TA	Calibration certificate	
TC	Material test certificate	
XF	SS tag plate, AISI 304 SS	
XG	SS tag plate, AISI 316 SS	
XT	Dial tag marking	
XR	Custom designed dial	
EG	Glycerin oil	
DS	Dual scale C/F	

Ordering Example : TB18D-05-XXX-D-HH-ER-150-KW-14N-BA

#### NOTES

- For other connections, please contact factory.
- 1/4" connections are available up to 1/4" (6.35 mm) stem diameter only.
- 3/8" connections are available up to 10 mm stem diameter only.

03/04

**RANGE TABLE**

<b>RANGE(°C)</b>	<b>CODE</b>
0...+50	C01
0...+60	C02
0...+80	C03
0...+85	C04
0...+100	C05
0...+120	C06
0...+150	C07
0...+160	C08
0...+200	C09
0...+250	C10
0...+300	C11
0...+350	C12
0...+400	C13
0...+450	C14
0...+500	C15
0...+550	C16
0...+600	C17
-20...+40	C18
-20...+50	C19
-20...+60	C20
-10...+50	C21
-10...+110	C22
-20...+80	C23
-20...+100	C24

<b>RANGE(°C)</b>	<b>CODE</b>
-20...+110	C25
-20...+120	C26
-20...+140	C27
-20...+180	C28
-25...+40	C29
-30...+50	C30
-30...+70	C31
-30...+100	C32
-40...+60	C33
-40...+80	C34
-40...+100	C35
-40...+120	C36
-40...+160	C37
-50...+50	C38
-50...+550	C39
-50...+100	C40
-50...+120	C41
-50...+200	C42
-50...+300	C43
-50...+500	C44
-70...+70	C45
-70...+30	C46
-10...+50	C47
-10...+110	C48