

FEATURES

- All SS measuring system
- Socket-case, direct welded
- Low pressure application (<0.6 bar)
- Zero adjustment on dial

APPLICATIONS

- Liquid & gaseous mediums
- Corrosive environments
- Oil & Gas applications
- Chemical & Petrochemical
- Food & Beverages
- Nuclear power plants

Capsule



STANDARD PARAMETERS

Accuracy	: CL 1.6
Ambient temperature	: -40...+65°C
Medium temperature	: -40...+150°C
Pressure limits	: Steady pressure up to FS value Fluctuating pressure up to %90 of FS value
Standard	: EN837-3

MATERIAL OF CONSTRUCTION

Sensing element	: Capsule
Case & Ring material	: AISI 304 SS (Bayonet type)
Capsule	: AISI 316 SS
Socket	: AISI 316 SS (Welded directly to case)
Movement mechanism	: Stainless steel
Dial	: Aluminum, black graduation on white background with external zero adjustment on dial
Pointer	: Fixed, aluminum, black powder coated
Gaskets, Blow off disc & filling plug	: NBR
Window	: Safety glass

STANDARD SPECIFICATIONS

Dial size	: 63mm (2.5") / 100mm (4") / 160mm (6")
Range	: 0...16 mbar 0...600 mbar -600...25...600 mbar 6...16 mbar (available in DN 160) 100...600 mbar
Mounting pattern	: Direct, Bottom connection
Process connection	: 1/2" NPT (M)
Ingress protection	: IP 65
Execution	: Dry

TEMPERATURE EFFECT

When temperature of the measuring system deviates from reference temperature (+20°C) max error $\pm 0.4\%$ / 10K of true scale value. (According to EN837)

Type A

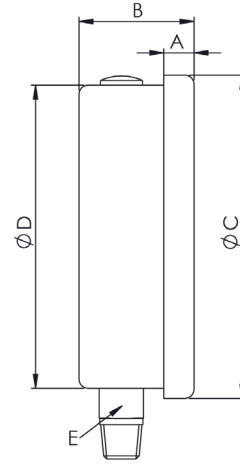
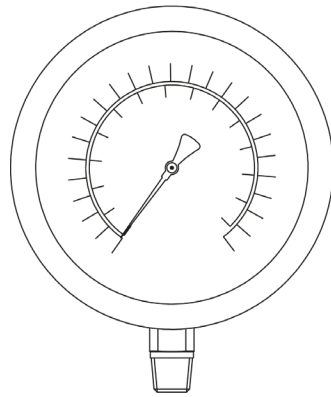

DN	A	B	C	D	E	Weight
100	17	50	100	98	SW24	~605 g
160	15	53	160	150	SW22	~963 g

Type C

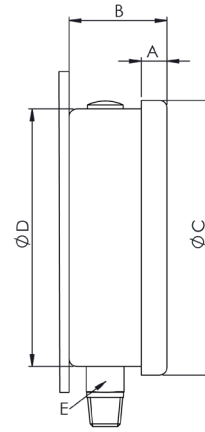
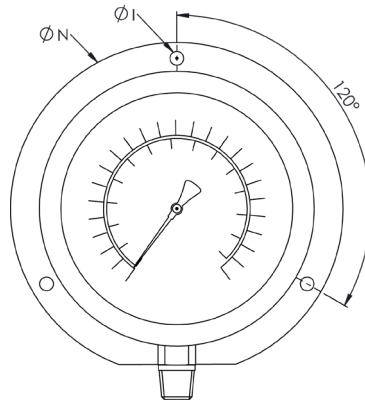

DN	A	B	C	D	E	U	I	N	Weight
100	17	50	100	98	SW24	132	5	109	~691 g
160	15	53	160	150	SW22	171	6	196	~1117 g

Type K

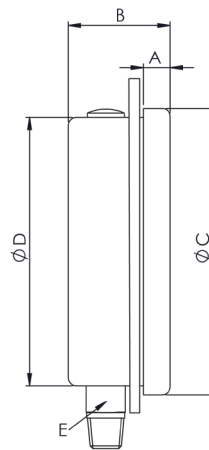
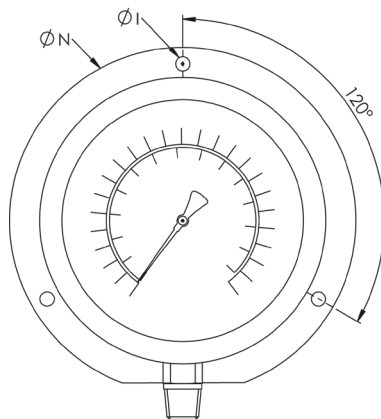

DN	A	B	C	D	E	U	I	N	Weight
100	17	50	100	98	SW24	132	5	109	~691 g
160	15	53	160	150	SW22	171	6	196	~1117 g

ORDERING CODES

1. DIAL SIZE

03	63 mm / 2½"	03
05	100 mm / 4"	
07	160 mm / 6"	

2. RANGE

XXX	Refer "Range Table"	XXX
-----	---------------------	-----

3. MOUNTING PATTERN

A	Direct, Bottom connection	A
B	Panel/bracket mounting, Lower Back connection	
C	Wall/Surface/mounting, Bottom connection	
D	Back connection	
E	Panel/Front flange mounting, Back connection	
G	2" Pipe/Yoke mounting, Bottom connection	
K	Panel/Front flange mounting, Bottom connection	

4. PROCESS CONNECTION

12B	¼" BSP (M)	
12N	¼" NPT (M)	
13B	3/8" BSP (M)	
14B	½" BSP (M)	
14M	M20 X 1.5 mm (M)	
14N	½" NPT (M)	14N

Other thread size and standards available on request

5. INGRESS PROTECTION

ER	IP 65	ER
----	-------	----

6. EXECUTION

EA	Dry	EA
----	-----	----

7. OTHER OPTIONS

BA	Case & Ring in AISI 316 SS	BA
TN	NACE standards	
TA	Calibration certificate	
TC	Material test certificate	
TO	Use for Oxygen service	
XF	SS tag plate, AISI 304 SS	
XG	SS tag plate, AISI 316 SS	
XR	Custom designed dial	
XT	Dial tag marking	

Ordering Example : PG9-18-03-XXX-A-14N-ER-EA-BA

NOTES

1. Case size is 150mm (D), Case+Ring=160mm (C)
2. For other connections, please contact factory.
3. Case & Ring in AISI 316 SS from DN100 onwards.
4. DN63 available in mounting pattern A and J only.
5. DN63 available with ¼" connections. Other connections through adaptors.

STANDARD RANGES

RANGE	"mbar"	RANGE	"kg/cm ² "	RANGE	"psi"	RANGE	"mmH ₂ O"
0...10	F01	0...0.01	K61	0...0.15	S51	0...100	H01
0...16	F03	0...0.016	K62	0...0.25	S52	0...160	H02
0...25	F05	0...0.025	K63	0...0.36	S53	0...250	H03
0...45	F07	0...0.045	K64	0...0.65	S54	0...450	H04
0...60	F09	0...0.06	K65	0...1.0	S55	0...600	H05
0...100	F11	0...0.1	K66	0...1.5	S56	0...1000	H06
0...160	F13	0...0.16	K67	0...2.5	S57	0...1600	H07
0...250	F15	0...0.25	K68	0...3.6	S58	0...2500	H08
0...400	F17	0...0.4	K69	0...6.0	S59	0...4000	H09
0...600	F19	0...0.6	K01	0...10	S01	0...6000	H10

Vacuum and +/- Scale Ranges

RANGE	"mbar"	RANGE	"mbar"
-10...0	V01	-5...+5	V21
-16...0	V03	-8...+8	V23
-25...0	V05	-20...+20	V25
-40...0	V07	-30...+30	V27
-60...0	V09	-50...+50	V29
-100...0	V11	-80...+80	V31
-160...0	V13	-125...+125	V33
-250...0	V15	-200...+200	V35
-400...0	V17	-300...+300	V39
-600...0	V19	-	-

NOTES

- Other scales & measurement units are available.
- Equivalent scales available in kg/cm², psi, kPa, MPa, bar/psi, kPa/bar, kPa/psi or any other special scales.
- Primary scales shall be in "BLACK" and secondary scales shall be "RED".
- Special scales, custom dial design, OEM/private logo printing is available, details contact our marketing team.