

FEATURES

- Safety pattern type
- All stainless steel system
- Dry / liquid filled

APPLICATIONS

- Oil & Gas applications
- High pressure applications
- Corrosive & Hazardous environments

Solid Front With Full Blow-out Back**STANDARD PARAMETERS**

Accuracy	: CL 1.0
Ambient temperature	: -40...+65°C (without dampening liquid) -20...+65°C (with dampening liquid)
Medium temperature	: -40...+200°C (without dampening liquid) -40...+100°C (with dampening liquid)
Pressure limits	: Steady pressure up to FS value Fluctuating pressure up to 90% of FS value Short time 1.3 x FS value
Standard	: EN837-1

MATERIAL OF CONSTRUCTION

Sensing element	: Bourdon Tube (C - type or Helical)
Case & Ring material	: AISI 304 SS (Bayonet type)
Bourdon tube & Socket	: AISI 316 SS (Socket welded directly to case)
Movement mechanism	: Stainless steel
Dial	: Aluminum, black graduation on white background
Pointer	: Micro-zero adjustable, aluminum, black powder coated
Gaskets & filling plug	: NBR
Window	: Safety glass
Baffle wall	: AISI 304 SS

STANDARD SPECIFICATIONS

Dial size	: 100mm (4") / 160mm (6")
Range	: -1...0...1,600 bar
Mounting pattern	: Direct, Bottom connection
Process connection	: ½" NPT (M) / ½" BSP (M)
Ingress protection	: IP 65
Execution	: Dry/ Dry but fillable

STANDARD SPECIFICATIONS : DAMPENING LIQUID FILLED, GLYCERIN

Window	: Safety glass
Dampening liquid	: Glycerin

TEMPERATURE EFFECT

When temperature of the measuring system deviates from reference temperature (+20°C) max error $\pm 0.4\%$ / 10K of true scale value. (According to EN837)

Type A

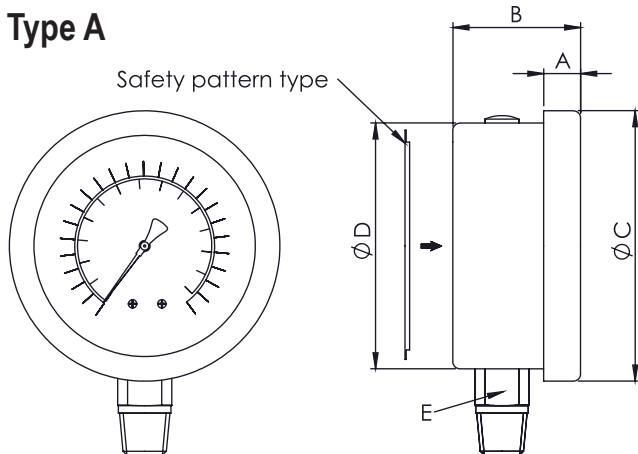

DN	A	B	C	D	E	Weight
100	15	57	110	100	sq22	~529 g
160	16	60	160	150	sq22	~1160 g

ORDERING CODES

1. DIAL SIZE

05	100 mm / 4"	05
07	160 mm ¹ / 6"	

2. RANGE

XXX	Refer "Range Table"	XXX
-----	---------------------	-----

3. MOUNTING PATTERN

A	Direct, Bottom connection	A
C	Wall/Surface/mounting, Bottom connection	
D	Back connection	
E	Panel/Front flange mounting, Back connection	
G	2" Pipe/Yoke mounting, Bottom connection	

4. PROCESS CONNECTION

12B	1/4" BSP (M)	
12N	1/4" NPT (M)	
13B	3/8" BSP (M)	
14B	1/2" BSP (M)	
14M	M20 X 1.5 mm (M)	
14N	1/2" NPT (M)	14N

Other thread size and standards available on request

5. INGRESS PROTECTION

ER	IP 65	ER
ET	IP 67	

6. EXECUTION

EA	Dry	EA
EB	Dry but fillable	
EG	Glycerine oil	
EH	Silicon oil	

7. OTHER OPTIONS

BA	Case & Ring in AISI 316 SS	BA
EM	Dampening screw, Monel	
EN	Dampening screw, AISI 316 SS	
EX	Internal overload stop	
EY	Internal vacuum stop	
EZ	Pointer stop on dial	
GL	AISI 316 SS movement	
GM	Dampened movement	
GX	Knife edge pointer	
MN	Monel wetted parts	
OP	Overrange protection 1.5xFS	
P8	Epoxy coating	
R9	Receiver gauge ²	
TA	Calibration certificate	
TC	Material test certificate	
TL	Helium leak testing	
TN	NACE standards	
TO	Use for Oxygen service	
TT	C.C. with NABL traceability	
XA	Accuracy: 0.5% of FS	
XF	SS tag plate, AISI 304 SS	
XG	SS tag plate, AISI 316 SS	
XR	Custom designed dial	
XT	Dial tag marking	

Ordering Example : PG20-05-XXX-A-14N-ER-EA-BA

NOTES

- Case size is 150mm (D), Case+Ring=160mm (C)
- Please specify the second scale required.
- For other connections, please contact factory.
- C.C. = Calibration Certificate

STANDARD RANGES

RANGE	"bar"	"kg/cm ² "	"bar / psi"	RANGE	"psi"	RANGE	"kPa"	RANGE	"MPa"
0...0.6	B01	K01	N01	0...10	S01	0...60	E01	-	-
0...1	B02	K02	N02	0...15	S02	0...100	E02	0...0.1	M02
0...1.6	B03	K03	N03	0...25	S03	0...160	E03	0...0.16	M03
0...2.5	B05	K05	N05	0...35	S05	0...250	E05	0...0.25	M05
0...4	B06	K06	N06	0...60	S06	0...400	E06	0...0.4	M06
0...6	B07	K07	N07	0...100	S07	0...600	E07	0...0.6	M07
0...10	B09	K09	N09	0...150	S09	0...1000	E09	0...1	M09
0...16	B11	K11	N11	0...235	S11	0...1600	E11	0...1.6	M11
0...25	B13	K13	N13	0...365	S13	0...2500	E13	0...2.5	M13
0...40	B16	K16	N16	0...600	S16	0...4000	E16	0...4	M16
0...60	B17	K17	N17	0...870	S17	0...6000	E17	0...6	M17
0...70	B18	K18	N18	0...1000	S18	0...7000	E18	0...7	M18
0...100	B19	K19	N19	0...1500	S19	0...10000	E19	0...10	M19
0...160	B21	K21	N21	0...2300	S21	0...16000	E21	0...16	M21
0...250	B24	K24	N24	0...3600	S24	0...25000	E24	0...25	M24
0...400	B27	K27	N27	0...6000	S27	0...40000	E27	0...40	M27
0...600	B29	K29	N29	0...8700	S29	0...60000	E29	0...60	M29
0...700	B30	K30	N30	0...10000	S30	0...70000	E30	0...70	M30
0...1000	B31	K31	N31	0...15000	S31	-	-	0...100	M31
0...1600	B34	K34	N34	0...23200	S34	-	-	0...160	M34
-1...0	B37	K37	N37	-	-	-100...0	E37	0.1...0	M37
-1...0.6	B38	K38	N38	-	-	-100...60	E38	-0.1...0.06	M38
-1...1.5	B39	K39	N39	-	-	-100...150	E39	-0.1...0.15	M39
-1...3	B42	K42	N42	-	-	-100...300	E42	-0.1...0.3	M42
-1...5	B43	K43	N43	-	-	-100...500	E43	-0.1...0.5	M43
-1...9	B45	K45	N45	-	-	-100...900	E45	-0.1...0.9	M45
-1...15	B47	K47	N47	-	-	-100...1500	E47	-0.1...1.5	M47
-1...24	B49	K49	N49	-	-	-100...2400	E49	-0.1...2.4	M49

NOTES

- Other scales & measurement units are available.
- Equivalent scales available in kg/cm², psi, kPa, MPa, bar/psi, kPa/bar, kPa/psi or any other special scales.
- Primary scales shall be in "BLACK" and secondary scales shall be "RED".
- Special scales, custom dial design, OEM/private logo printing is available, details contact our marketing team.