

FEATURES

- Single side static sustainable
- Static pressure 200 bar max.
- Dry / liquid filled

APPLICATIONS

- Liquid & gaseous media
- Corrosive environments
- Oil & Gas applications
- Chemical & Petrochemical
- Level measurement in closed tank
- Filter monitoring

Double Diaphragm



STANDARD PARAMETERS

Accuracy*	: CL 1.6
Ambient temperature	: -40...+60°C (without dampening liquid) -20...+60°C (with dampening liquid)
Service temperature	: 150°C max.
Static pressure	: 16...60 mbar : 25 bar 100 mbar...25 bar : 40 bar
Over-pressure safety	: 400 bar for ranges 0.4...0 bar up to 40...0 bar
Pressure limits	: Steady pressure up to F.S value Fluctuating pressure up to 96% of F.S value
Standard	: EN837-3

MATERIAL OF CONSTRUCTION

Sensing element	: Diaphragm
Case & Ring material	: AISI 304 SS (Bayonet type)
Diaphragm	: AISI 316 SS
Chamber	: AISI 316 SS
Movement mechanism	: Stainless Steel
Transmission chamber dampening liquid	: Silicon oil
Chamber sealing gaskets	: NBR
Dial	: Aluminum, black graduation on white background
Pointer	: Micro-zero adjustable, aluminum, black powder coated
Gaskets & filling plug	: NBR
Window	: Safety Glass

STANDARD SPECIFICATIONS

Dial size	: DN100 / DN160
Range	: 0...16 mbar...40 bar
Mounting pattern	: Direct, Bottom connection
Process connection	: ¼" NPT (F) x 2 Nos (37mm center to center)
Ingress protection	: IP 65
Execution	: Dry / Dry but fillable

*At 20°C and Zero static pressure.

STANDARD SPECIFICATIONS : DAMPENING LIQUID FILLED, GLYCERIN

Accuracy	: CL 2.5
Window	: Safety glass
Dampening liquid	: Glycerin

TEMPERATURE EFFECT

When temperature of the measuring system deviates from reference temperature (+20°C) max error $\pm 0.6\%$ / 10K of true scale value. (According to EN837)

DIMENSIONAL DRAWING

Type A

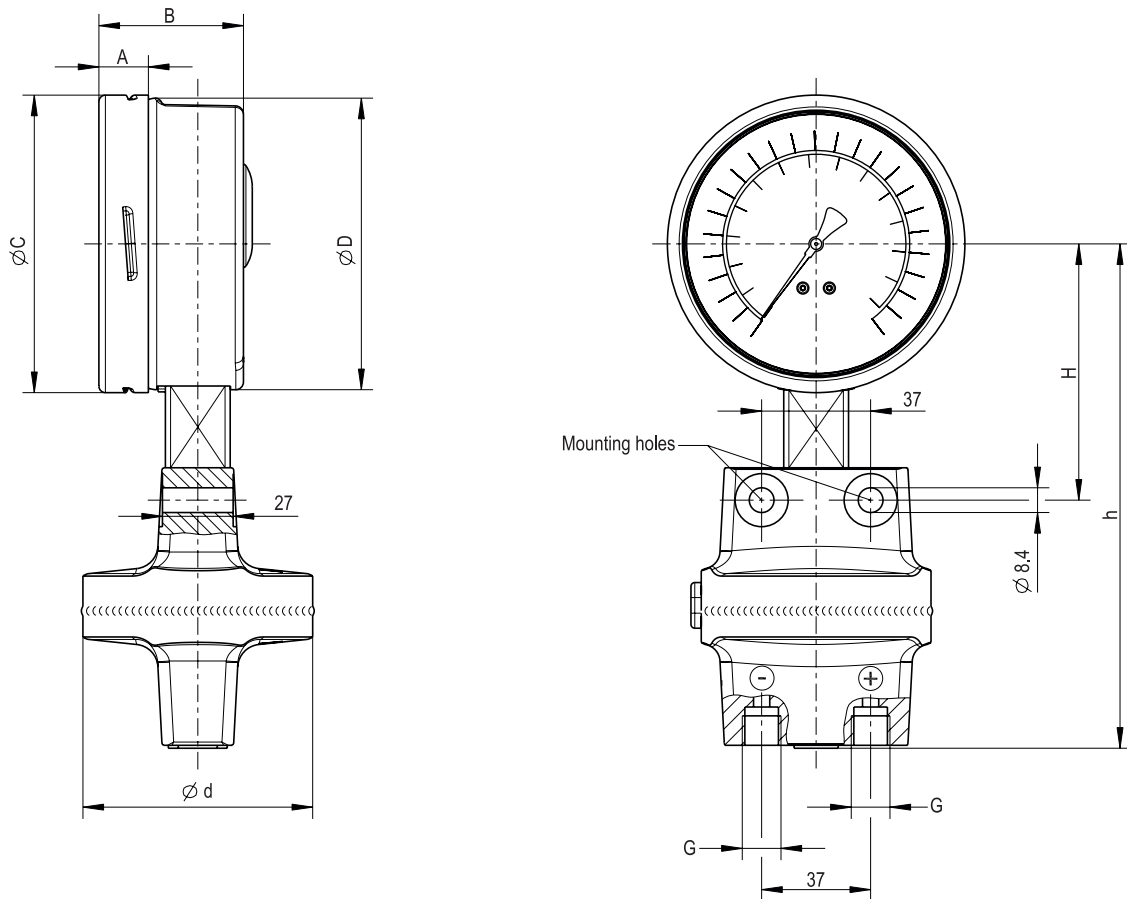

DN	G	A	B	C	D	d	H	h	Weight
100	G $\frac{1}{4}$	16.9	49.7	101	98.5	75	83	178.5	~1796 g
160	G $\frac{1}{4}$	17.5	59	161	159	78	117	200	-

ORDERING CODES**1. DIAL SIZE**

05	100 mm / 4"	05
07	160 mm ¹ / 6"	

2. RANGE

XXX	Refer "Range Table"	XXX
------------	---------------------	------------

3. MOUNTING PATTERN

A	Direct, Bottom connection	A
G	2" Pipe/Yoke mounting, Bottom connection	

4. PROCESS CONNECTION

02N	1/4" NPT (F) x 2 Nos.	02N
13B	3/8" BSP (M) x 2 Nos.	
14B	1/2" BSP (M) x 2 Nos.	
14M	M20 X 1.5 mm (M) x 2 Nos.	
14N	1/2" NPT (M) x 2 Nos.	
04N	1/2" NPT (F) x 2 Nos.	
Other thread size and standards available on request		

* Male threads through adaptors

5. INGRESS PROTECTION

ER	IP 65	ER
-----------	-------	-----------

6. EXECUTION

EA	Dry	EA
-----------	-----	-----------

7. OTHER OPTIONS

BA	Case & Ring in AISI 316 SS	BA
DM	Monel diaphragm	
DO	Hastelloy C-276 diaphragm	
GW	Maximum reading pointer	
TA	Calibration certificate	
TC	Material test certificate	
TN	NACE standards	
XF	SS tag plate, AISI 304 SS	
XR	Custom designed dial	
XT	Dial tag marking	
CA	Connector Male to Male adaptor	

Ordering Example : PG13-700-05-XXX-A-02N-ER-EA-BA**NOTES**

1. Case size is 150mm (D), Case+Ring=160mm (C)

03/04

STANDARD RANGES

RANGE	"bar"	"kg/cm ² "	"bar / psi"	RANGE	"psi"	RANGE	"kPa"	RANGE	"MPa"
0...0.6	B01	K01	N01	0...10	S01	0...60	E01	-	-
0...1	B02	K02	N02	0...15	S02	0...100	E02	0...0.1	M02
0...1.6	B03	K03	N03	0...25	S03	0...160	E03	0...0.16	M03
0...2.5	B05	K05	N05	0...35	S05	0...250	E05	0...0.25	M05
0...4	B06	K06	N06	0...60	S06	0...400	E06	0...0.4	M06
0...6	B07	K07	N07	0...100	S07	0...600	E07	0...0.6	M07
0...10	B09	K09	N09	0...150	S09	0...1000	E09	0...1	M09
0...16	B11	K11	N11	0...235	S11	0...1600	E11	0...1.6	M11
0...25	B13	K13	N13	0...365	S13	0...2500	E13	0...2.5	M13
0...40	B16	K16	N16	0...600	S16	0...4000	E16	0...4	M16
Other Range	B00	K00	N00	Other Range	S00	Other Range	E00	Other Range	M00

RANGE	"mbar"	RANGE	"kg/cm ² "	RANGE	"psi"	RANGE	"mmH ₂ O"
0...60	F09	0...0.06	K65	0...1.0	S55	0...600	H05
0...100	F11	0...0.1	K66	0...1.5	S56	0...1000	H06
0...160	F13	0...0.16	K67	0...2.5	S57	0...1600	H07
0...250	F15	0...0.25	K68	0...3.6	S58	0...2500	H08
0...400	F17	0...0.4	K69	0...6.0	S59	0...4000	H09
0...600	F19	0...0.6	K01	0...10	S01	0...6000	H10

NOTES

- Other scales & measurement units are available.
- Equivalent scales available in kg/cm², psi, kPa, MPa, bar/psi, kPa/bar, kPa/psi or any other special scales.
- Primary scales shall be in "BLACK" and secondary scales shall be "RED".
- Special scales, custom dial design, OEM/private logo printing is available, details contact our marketing team.